

# LUMBER STACKER

## PACKAGE MAKER

- Fast
- Rugged
- Versatile

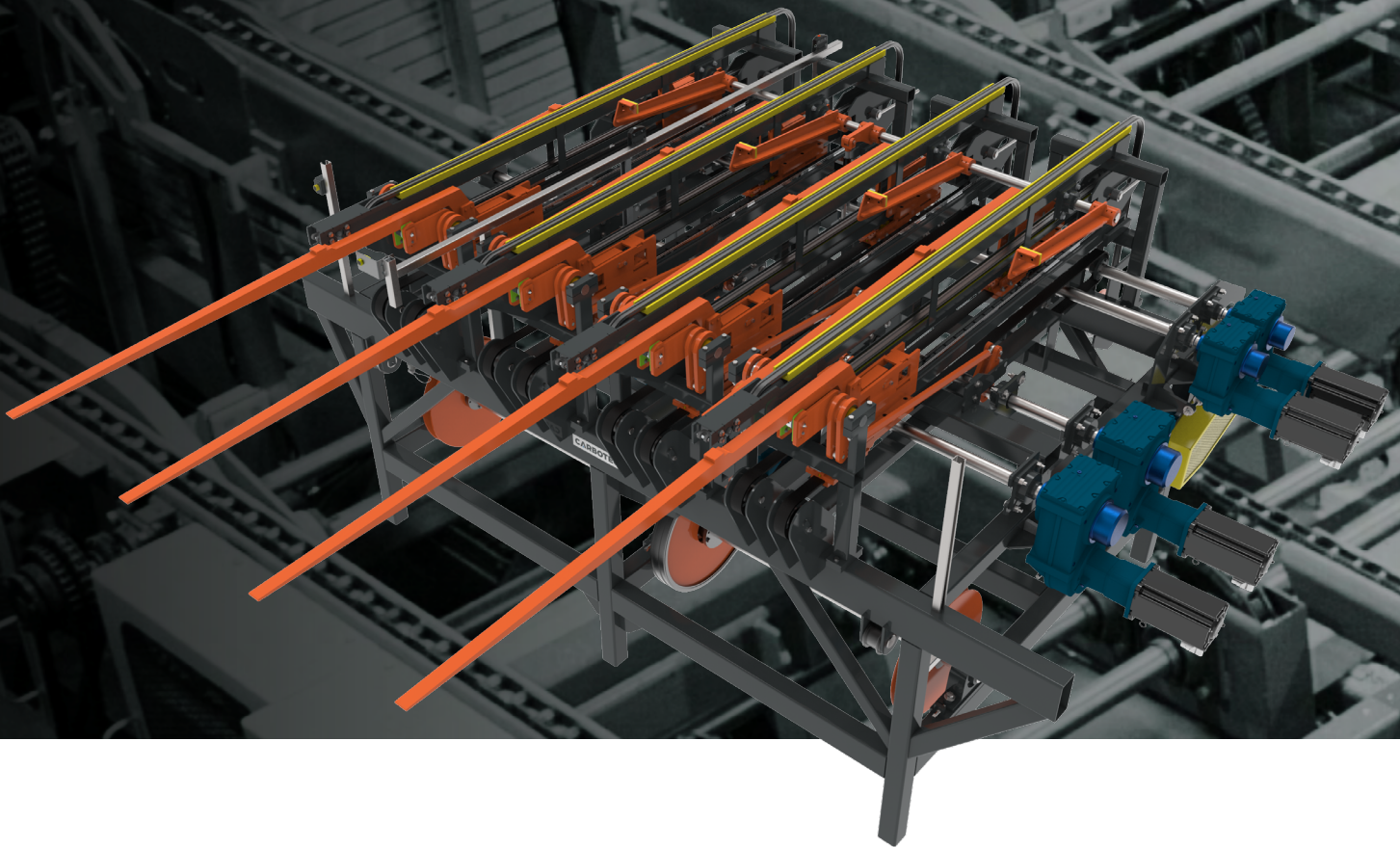

**CARBOTECH**

[carbotech.ca](http://carbotech.ca)



## APPLICATIONS

- Sawmill and planer mill packages
- Hardwood and softwood mills
- Low and high-speed processes
- Speeds up to 22 rows/minute

## FEATURES

- Double-fork design for high speed available
- Secondary hoist for continuous stacking
- Automatic stick infeed system
- Integrated bundle squaring devices
- Minimal operator intervention required
- All-electric
- Safe and easy maintenance access

## BOARD SIZES

- Heights up to 8' (2,5 m)
- Widths 3' to 8' (1 to 2,5 m)
- Lengths 4' to 28' (1,2 to 8,5 m)